

In designing TECTROL'S liquid level control, we use two principles of operation that have become the industry standard: Archimedes Principle and the Cantilever Beam. Our goal was to manufacture a product that the "field people" could understand its operation and perform basic repairs themselves.

TECTROL'S liquid level control uses a sensing rod with an attached displacer on the end. With the rising of the fluid you have the static lift force that allows your actuator pad to move closer to the nozzle, diverting your supply pressure to a diaphragm operated motor valve. As the fluid drains, your level drops and the pad moves away from the nozzle, resulting in the relief of the supply pressure and the diaphragm operated motor valve closes. You are throttling the valve to maintain a set fluid level in the urrit.

Using this method of control you can sense and regulate levels of gas to fluid interface applications as well as many fluid to fluid interfaces.

Should you desire a snap action of this unit you could do this by purchasing TECTROL'S Snap Pilot and make the correct adjustment to our control head.

TECTROL'S Liquid Level Control is easy to adjust in the field, making it a product that is going to deliver your products in the most cost effective method.

Our liquid level control is available In different sizes; 2" threaded, 4" hammer union, 5" hammer union, and flanged.

*We welcome special order and custom built level controls.*

**CAUTION: WHEN REMOVING THE LIQUID LEVEL CONTROL FROM THE VESSEL, MAKE SURE ALL PRESURE IS OFF THE VESSEL, SUPPLY GAS IS OFF AND DISCONNECTED, AND UNIT IS DRAINED OF FLUID. YOU SHOULD INSURE THAT THE VENTED GAS IS PIPED AWAY FROM THE CONTROLLER WHERE IT WILL NOT EFFECT PERSONNEL OR THE ENVIRONMENT. USE CAUTION IF THIS PRODUCT IS BEING USED IN A HAZARDOUS MATERIAL ENVIRONMENT (H<sup>2</sup>S OR CO<sub>2</sub>), ETC.**

**LIQUID LEVEL CONTROL  
4" PNEUMATIC 1500 PSIG  
MODEL 4-LLC**



**LIQUID LEVEL CONTROL**

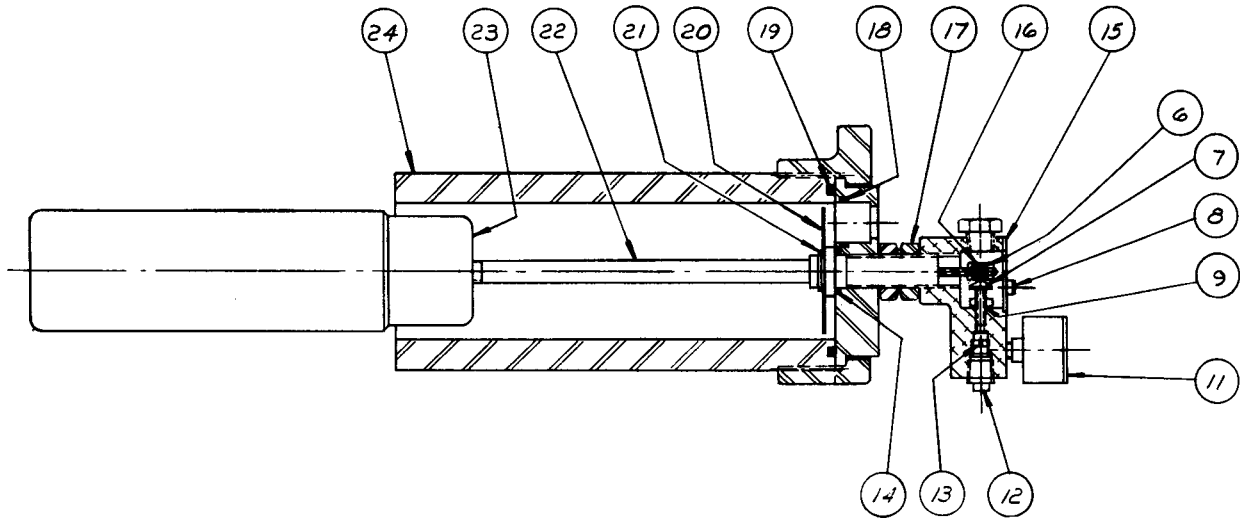

Item	Qty.	Description	Part No.
1	1	Hammer Nut	0003-00364
2	1	Sight Glass Flange	0003-00329
3	1	Breather	0003-00319
4	1	Housing	0003-00308
5	3	Sight Glass	0003-00347
6	2	Hex Nut Stainless Stl	0003-00354
7	1	Nozzle	0003-00313
8	2	Pan Ho Screw	0003-00323
9	1	O-Ring	0003-00317
10	1	Hex Nut Stainless Stl	0003-00315
11	2	Gauge 30PSI	0003-00325
12	1	Pipe Plug	0003-00312
13	1	Orifice	0003-00310
14	1	O-Ring	0003-00352
15	1	Cover Plate	0003-00321
16	1	Seat	0003-00356
17	2	Jam Nut	0003-00358
18	3	O-Ring	0003-00345
19	1	O-Ring	0003-00368
20	1	Reflector	0003-00360
21	1	Retaining Ring	0003-00362
22	1	Sensing Rod Assy.	0003-00350
23	1	Displacer	0003-00376
24	1	Weldneck	0003-00372

